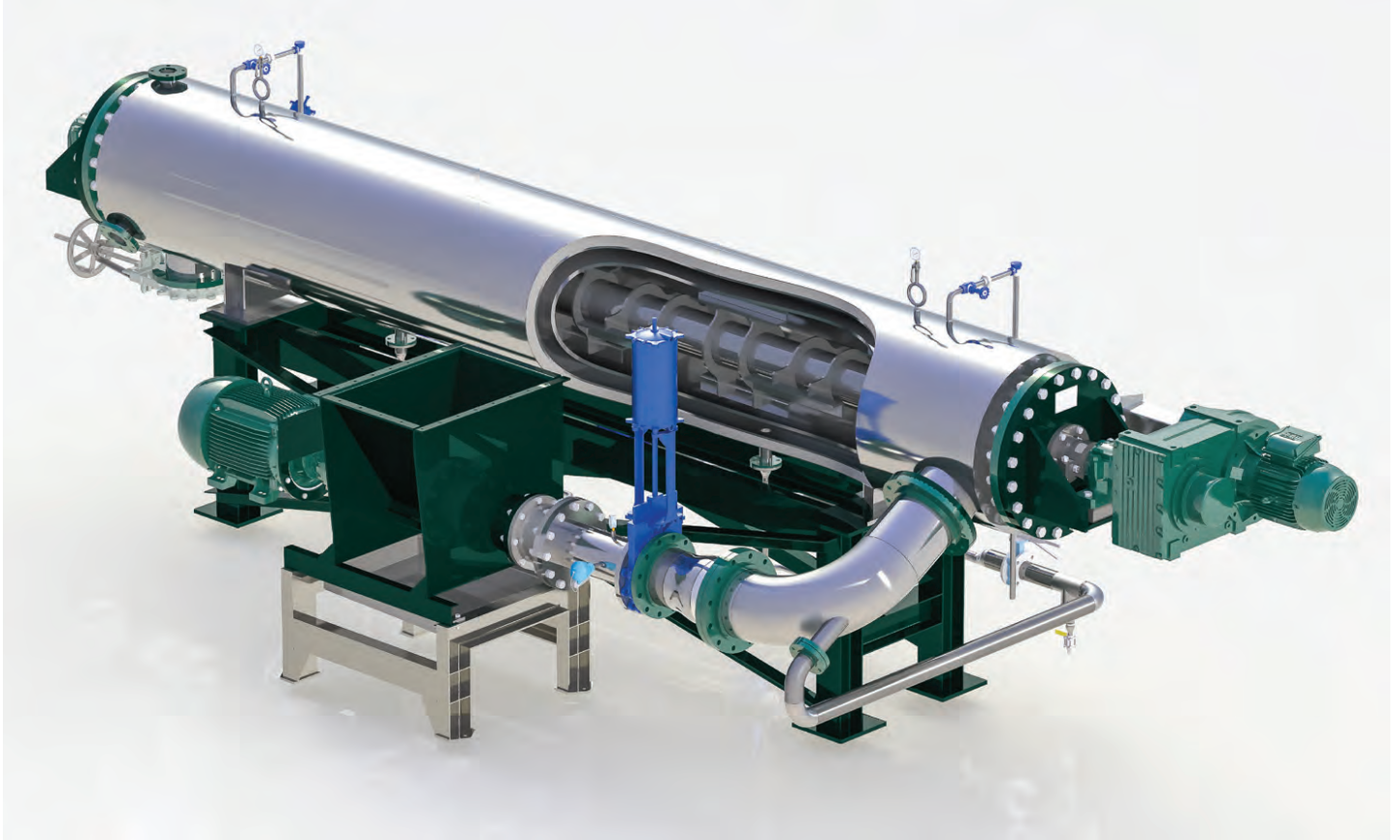

CONTINUOUS FEATHER HYDROLYSER

RENDETECH

The Rendertech Continuous Feather Hydrolyser converts poultry feathers and hog hair into a highly nutritional animal feed. It is simple to operate and maintain with automated controls. Features include an integrated drainer section in the feeder to remove excess water and thus improve efficiency. The steam-heated jacket and direct steam injection produce a consistent finished product.

PRODUCT QUALITY

A combination of short retention time and high pressure ensures the best combination of digestibility and protein levels. Continuous operation assures consistent high quality amino acid profile.

HIGH EFFICIENCY

The Hydrolyser includes a pressing stage in the feed hopper to expel free water and ensure energy is not wasted on processing excess water. The discharge system from the hydrolyser results in a high level of flash steam. This gives a drier product and reduces drying costs. Electrical power consumption is low. External insulation is supplied as standard.

SIMPLE OPERATION

The Hydrolyser is continuous and fully

automated, from the controls through to the feed plug management, and so requires minimal operator monitoring.

LOW MAINTENANCE

The high-strength carbon steel shaft has stainless steel cladding, and all internal surfaces are stainless steel for easy cleaning and extended life. This makes for a proven reliable design with minimal maintenance.

ODOUR CONTROL

The fully sealed inlet and outlet of the Hydrolyser ensures simple capture and treatment of vapour and odours.

DRYING

The hydrolysed feathers are discharged into a hopper before feeding to a rotary or steam-heated disc drier.

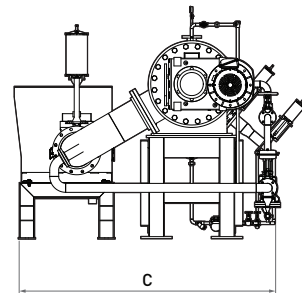
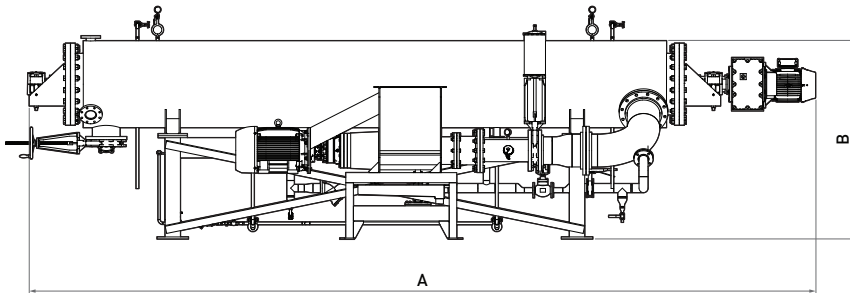
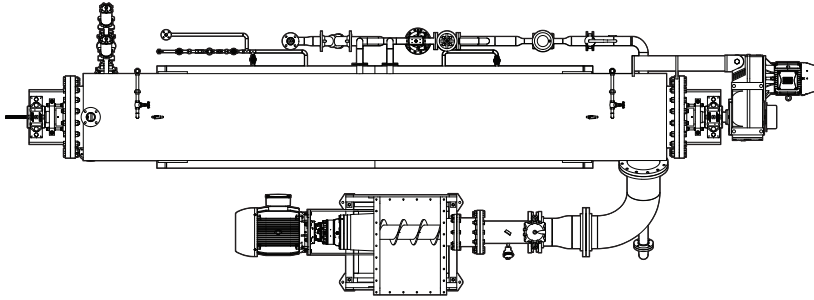

	CFH4.5	CFH5.5
TECHNICAL SPECIFICATION		
Throughput (kgs/hr), up to	4,500	5,500
PRODUCT DIMENSIONS		
Dimension A (mm)	7,735	7,790
Dimension B (mm)	1,975	2,115
Dimension C (mm)	2,160	2,200

YOUR PROCESS PARTNER

We are specialists in process and storage solutions, providing the products and technical expertise to get the best from your plant. For more information call for a no obligation chat about your processing needs.

E enquiries@rendertech.co.nz
T +64 9 634 5375

Rendertech Ltd
2/110 Mays Road, Onehunga,
Auckland 1061, New Zealand
PO Box 12629, Penrose,
Auckland 1642, New Zealand

RENDETECH.CO.NZ